

22-23
MAY
2024

Conference Programme

Day 1 (22 May 2024)

1

Military EMC & Protection Methods

Gavin Barber
QinetiQ Ltd



09:00 - 09:30 Reverberation chamber for military equipment testing
Sam Patient - QinetiQ Ltd

09:30 - 10:00 High power radio frequency directed energy weapons
Dr Richard Hoad - QinetiQ Ltd

10:00 - 10:30 RF shielding effectiveness measurements
Richard Hardy - AQL Ltd

10:30 - 11:00 Coffee/Tea Break in **Exhibiton** Area

2

Design for EMC

James Pawson
Unit 3 Compliance

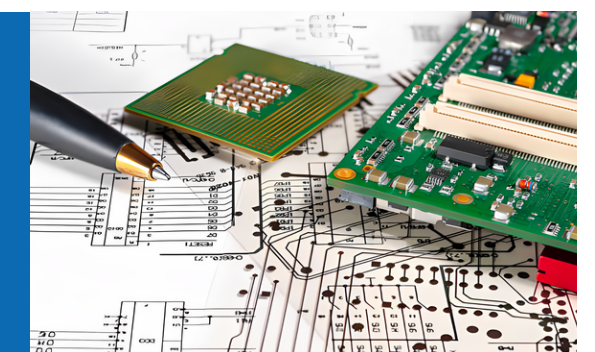

11:00 - 11:30 Radiated emissions made easy
Francesco Poderico - Neutronix Ltd

11:30 - 12:00 EMC design considerations for ATEX (explosive atmosphere) environments
Peter Rawlinson

12:00 - 12:30 Practical EMC design considerations
Mohamed AlAlami - Würth Electronics

12:30 - 13:00 Lunch Break

13:00 - 13:45 Keynote speaker - New EMC regulations - **Holger Urban** from **Schaffner**

13:45 - 14:00 Demo & Hands-on

3

EMC Simulations

Dr Tamara Monti
Dassault Systèmes

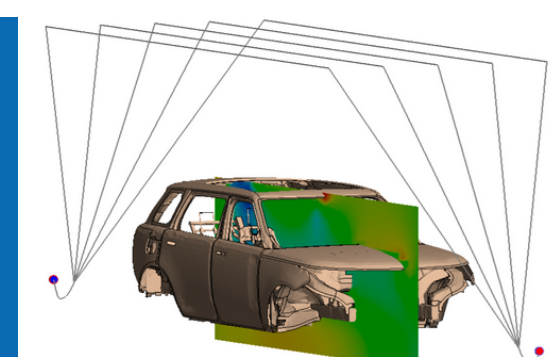

14:00 - 14:30 Vehicle RF filters - simulation and measurement
Dr Chris Davenport - Jaguar Land Rover

14:30 - 15:00 Echoes in a Biscuit Tin
Dr Graham Robert - Leonardo

15:00 - 15:30 Introduction to EMC Simulation
Dr. Sajid Asif - DASSAULT SYSTEMES

15:30 - 16:00 Coffee/Tea Break in **Exhibition** Area

16:00 - 18:00 Social Events and IEEE Talk

www.emcandci.com

Dubai Duty-Free Grandstand, Newbury Racecourse, Newbury, Berkshire, RG14 7NZ

22-23
MAY
2024

Conference Programme

Day 2 (23 May 2024)

4

EMC Systems and Installations

Prof. Ian Macdiarmid



09:00 - 09:30

An investigation into low level swept current (llsc) testing on land vehicles

Michael Airey

09:30 - 10:00

Electromagnetic Challenges in Naval Platform Topside Design - A Prime Integrator's Perspective and Approach

Jon Burbage - BAE systems

10:00 - 10:30

Model-based engineering is not "no testing"

Prof. Chris Jones - BAE Systems Air

10:30 - 11:00

Coffee/Tea Break in **Exhibitor Area**

5

Practical Compliance

Wil Corker
bp pulse



11:00 - 11:30

First time success

Wil Corker - bp pulse

11:30 - 12:00

Inside the approvals lab

Scott Liffen - BSI

12:00 - 12:30

EMC reality - A compliance manager's guide

Marc Hudson - Ransomes Jacobsen

12:30 - 13:00

Lunch Break

13:00 - 13:45

Keynote speaker - EMC Testing Essentials - *James Pawson*

13:45 - 14:00

Demo & Hands-on

6

EMC for Emerging Power Systems

Dr Oskari Leppäaho
Danfoss Drives



14:00 - 14:30

A technical review of EMI filters for electrification

Dr Min Zhang - Mach One Design

14:30 - 15:00

Common mode voltage management in electrification solutions

Dr Oskari Leppäaho - Danfoss Drives

15:00 - 15:30

Railway EMC and safety assurance

Simon Price

15:30 - 16:00

Coffee/Tea Break with panel discussions

www.emcandci.com

Dubai Duty-Free Grandstand, Newbury Racecourse, Newbury, Berkshire, RG14 7NZ